

# AR-B6051

3.5" Intel Atom E640 1GHz SBC

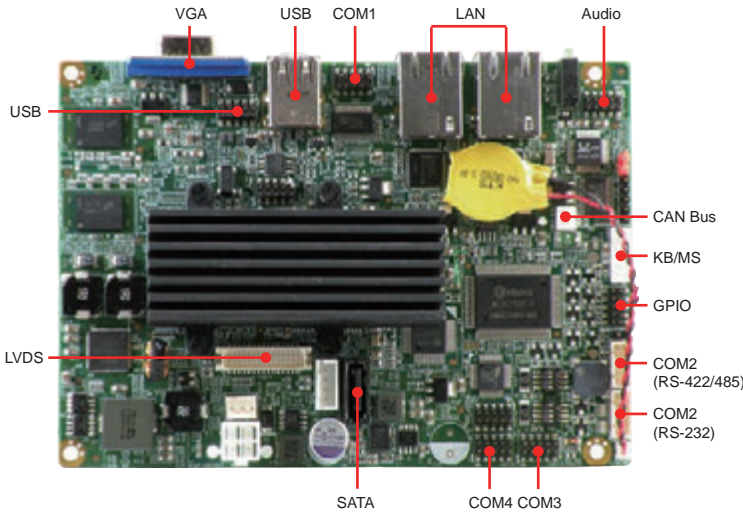

## Features

- Intel Atom E640 1GHz
- Onboard DDR2 1GB
- VGA/LVDS
- 2 x GbE, 4 x COM, 4 x USB 2.0, SATA, CF, CAN bus
- Mini PCIe Expansion



## Specification

### System

CPU	Intel Atom E640 1GHz
Chipset	Intel EG20T
Memory	Onboard DDR2-800 1GB
BIOS	Phoenix
Hardware Monitoring	<ul style="list-style-type: none"> <li>• CPU voltage and temperature</li> <li>• Fan speed</li> </ul>
WatchDog Timer	Software programmable 1~255 sec. (+/- 5%)

### Video

Graphic Controller	Intel Atom E600 series intergrated graphic engine
Videoe Memory	Maximum 64MB shared
Video Interface	<ul style="list-style-type: none"> <li>• 1 x VGA (DB15)</li> <li>• 1 x 18/24-bit LVDS (Pin header)</li> </ul>

### Storage

IDE	N/A
SATA	1 x SATA II port
CF	1 x Compact Flash Type I/II slot

### I/O

Ethernet	2 x GbE RJ45 with LED, Intel 82574L
Expansion Slot	<ul style="list-style-type: none"> <li>• 1 x Mini PCIe slot</li> <li>• 1 x CAN Bus</li> </ul>
Serial Port	<ul style="list-style-type: none"> <li>• 3 x RS-232 (3 x pin header)</li> <li>• 1 x RS-232/422/485 (JST, COM2)</li> </ul>
USB	4 x USB 2.0 (2 x external port, 2 x pin header)
GPIO	8-bit Digital I/O
PS/2	1 x KB/MS (Pin Header)
Audio	Realtek ALC662 Audio Codec

### Power Requirement

Power Input	12V (+/-5%) single voltage input
Power Consumption	19.38W, 1.62A @ 12V

### Software

OS Support	Windows XP 32-bit, Fedora 14 32 / 64-bit, Ubuntu 10.04 32 / 64-bit
------------	--

## Mechanical & Environment

Dimension	146mm x 102mm (5.7" x 4")
Operating Temp.	0~50°C (32~122°F)
Storage Temp.	-20~80°C (-4~176°F)
Safety	CE, FCC compliant

## Packing List

- 1 x AR-B6051E64
- 1 x Driver CD
- 1 x Quick Manual
- 1 x Audio cable

## Ordering Information

AR-B6051E64	3.5" SBC supports Intel Atom E640 1GHz, onboard DDR2, GbE, USB 2.0, VGA, LVDS, COM, SATA, CF, Mini PCIe
ACC-6051:	<ul style="list-style-type: none"> <li>• 1 x SATA + SATA Power cable</li> <li>• 3 x COM cable (for COM1, COM3 &amp; COM4)</li> <li>• 1 x COM cable (JST, for COM2 RS-232)</li> <li>• 1 x COM cable (JST, for COM2 RS-422/485)</li> <li>• 1 x USB cable</li> <li>• 1 x KB/MS Y cable</li> </ul>
Accessory (Optional)	

## Dimension

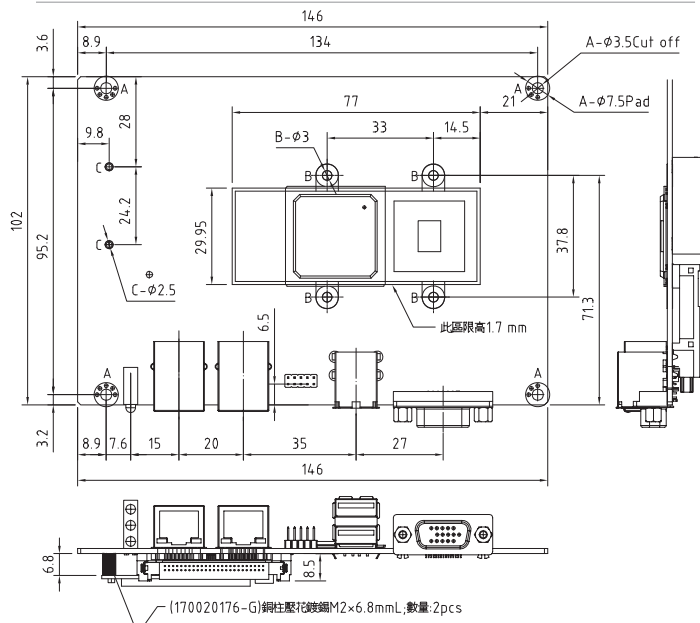

Specifications are subject to change without notice.