

VIO-W115/MX100

15.6" Full HD Resistive / Capacitive Touch Monitor
with 2x 10W Speaker

FEATURES

- 15.6" TFT Full HD 16:9 LCD with Resistive 5-wire / Projected Capacitive Touch
- 1x VGA, 1x DVI-D, 1x DisplayPort, 1x USB 2.0, 1x COM, 1x Audio
- 9 to 48VDC wide range power input
- -10°C to 60°C extended operating temperature
- Designed with Aluminum Die-Casting Front Frame
- IP65 Compliant Front Panel
- Two 10W Internal Speakers Built-in
- Multi-language OSD built-in



SPECIFICATIONS

DISPLAY

LCD Size	15.6" (16:9)
Max. Resolution	1920 x 1080 (Full HD)
Brightness (cd/m ²)	400
Contrast Ratio	700:1
LCD Color	16.7M
Pixel Pitch (mm)	0.17925 (H) x 0.17925 (V)
Viewing Angle (H-V)	160 / 140
Backlight MTBF	50000 hrs (LED Backlight)

TOUCH

Resistive 5-wire	VIO-W115HR/MX100 only
Projected Capacitive	VIO-W115HC/MX100 only

I/O

VGA Input	1x VGA Input
DVI-D Input	1x DVI-D Input
DisplayPort Input	1x DisplayPort Input
USB 2.0 Input	1x USB 2.0 Input
COM Port Input	1x COM Port Input
Audio Input	1x Audio Input

OTHER FEATURES

Internal Speaker	AMP 10W + 10W
OSD	LCD On/Off, Auto, Menu, Up and Down Multi-language

POWER

Power Supply Voltage	9~48VDC
Power Connector	3-pin Terminal Block
Power Adaptor	Optional AC/DC 12V/5A, 60W
Power Protection	OVP (Over Voltage Protection) OCP (Over Current Protection) Reverse Protection

ENVIRONMENT

Operating Temp.	-10°C to 60°C
Storage Temp.	-20°C to 70°C
Relative Humidity	10%~80% (non-condensing)
IP Level	IP 65 Compliant Front Panel
Vibration	1.5 Grms, 5 - 500 Hz, 0.5 hr/axis
Shock	20G, half sine, 11ms
Standards / Certification	CE, FCC Class A

PHYSICAL

Front Panel Construction	Die-cast Flat Surface
Dimension	432 (W) x 261 (D) x 70.7 (H) mm
Weight	VIO-W115R/MX100: 5.66 kg VIO-W115C/MX100: 5.60 kg
Mounting	VESA Mounting Holes 75 x 75mm, 100 x 100mm

Rear I/O

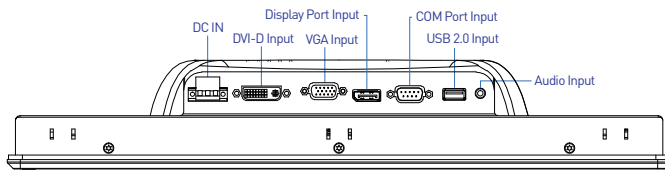

Right I/O

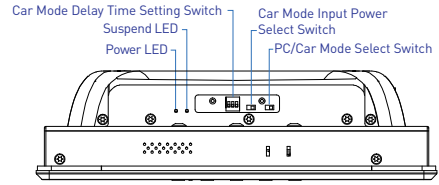

DIMENSION

Unit: mm

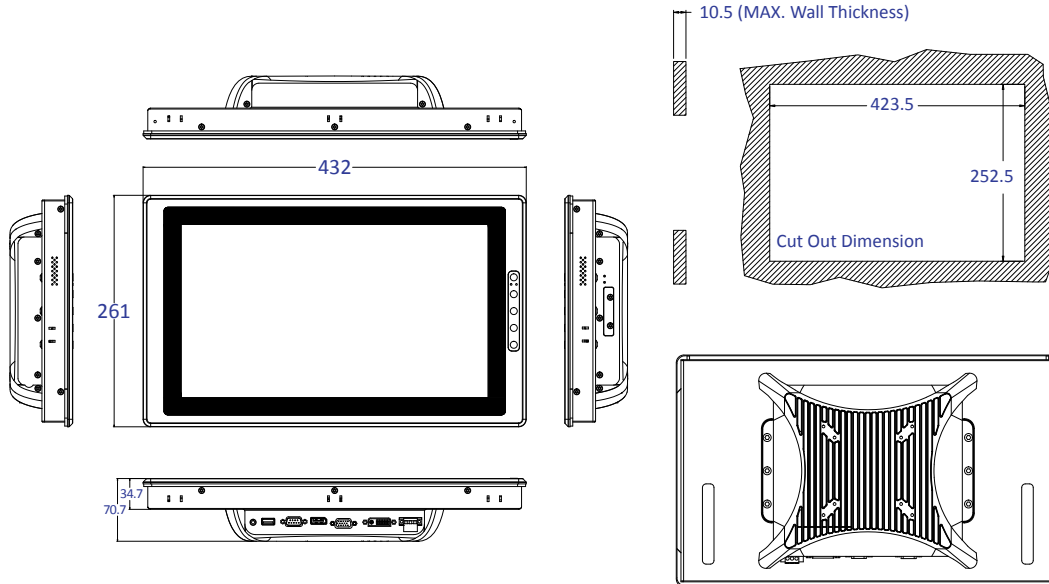

AVAILABLE MODELS

MODEL NO.	DESCRIPTION
VIO-W115R/MX100	15.6" 16:9 Full HD Resistive Touch Monitor with 2x 10W Speaker
VIO-W115C/MX100	15.6" 16:9 Full HD Capacitive Touch Monitor with 2x 10W Speaker

OPTIONAL ACCESSORIES

MODEL NO.	DESCRIPTION
1-E09A06002	Adapter AC/DC 12V 5A 60W with 3pin Terminal Block Plug 5.0mm Pitch
SFICBL022	Power Cord, 3-pin US Type, 180cm
1-TPCD00002	Power Cord, European Type, 180cm
1-TPCD00001	Power Cord, 3-pin UK Type, 180cm

PACKING LIST

- 1x VIO-W115/MX100 Series Touch Monitor
- 8x Panel Mount Kit
- 1x USB Cable
- 1x VGA Cable
- 1x Screw Pack