

# Apacer

The Most **Reliable**  
Storage For Industries

**Industrial SDHC 5.1 H2-M**

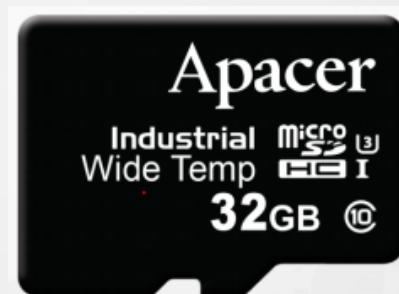

## ST170-7LP2

### Overview

Apacer SD H2-M is compatible with the SD card version 5.1. The command list supports [Physical Layer Specification Ver5] definitions. Card Capacity of Non-secure Area, Secure Area Supports [Security Specification Ver5] Specifications. Random performance of SD H2-M is much more enhanced than H1-M. The maximum transfer speed can be achieved along with UHS-I compliant devices. Besides, Video Speed Class is compliant with V10 and V30, which are mainly useful for camcorders, video recorders and other devices with video recording capabilities. With V10 and V30 speed mode, SD card is recommended for high resolution and high quality 4K video recording. Apacer SD H2-M card is also compliant with Application Performance Class A1, optimized for 4K small file random read/write IOPS, delivering minimum read/write performance at 1,900/800 IOPS at least.

The SD 5.1 card comes with 9-pin interface, designed to operate at maximum operating frequency of 50MHz or 100MHz. It can alternate communication protocol between the SD mode and SPI mode and is backward compatible with SD 2.0 devices. It performs data error detection and correction with very low power consumption.

Apacer Industrial SD 5.1 card with high performance, reliability and compatibility is well adapted for hand-held applications, medical, surveillance systems and automotive markets.



## ST170-7LP2

### Feature

- Built-in advanced ECC algorithm
- Global Wear Leveling
- Flash bad-block management
- Page Mapping
- S.M.A.R.T.
- Power Failure Management
- Read Disturb Management

## Specifications

<b>Model</b>	Industrial SDHC 5.1 H2-M
<b>Interface</b>	The SD 5.1 card comes with 9-pin
<b>Form Factor</b>	SD
<b>NAND Flash Type</b>	MLC
<b>Capacity</b>	SDHC: 4GB~32GB
<b>External DRAM</b>	No
<b>Sustained Read Performance (MB/sec)</b>	Up to 90
<b>Sustained Write Performance (MB/sec)</b>	Up to 42
<b>ECC Engine</b>	Built-in 42-bit per 1K bytes BCH ECC
<b>IOPS (4K Random Write)</b>	Up to 800
<b>Standard Operating Temperature ( °C )</b>	-25 ~ + 85
<b>Storage Temperature ( °C )</b>	-40 ~ + 85
<b>Shock</b>	(Operating)1,500G, 0.5ms
<b>Vibration</b>	20Hz~80Hz/1.52mm (frequency/displacement) 80Hz~2,000Hz/20G (frequency/accelerate)
<b>Operating Voltage</b>	2.7V ~ 3.6V
<b>Power Consumption</b>	Active mode: 105 mA & Idle mode: 270 uA
<b>Dimension (L x W x H)</b>	24mm x 32mm x 2.1mm
<b>MTBF (hours)</b>	>3,000,000

## Mechanical Specification

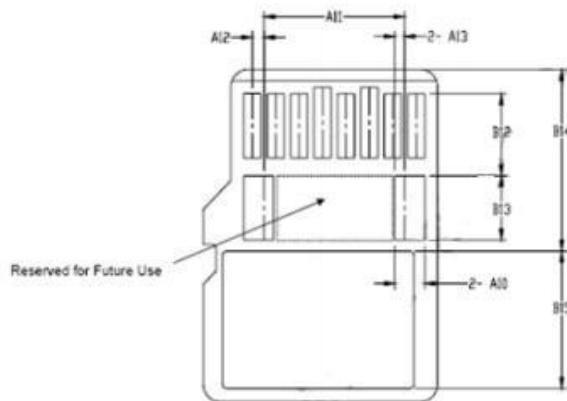
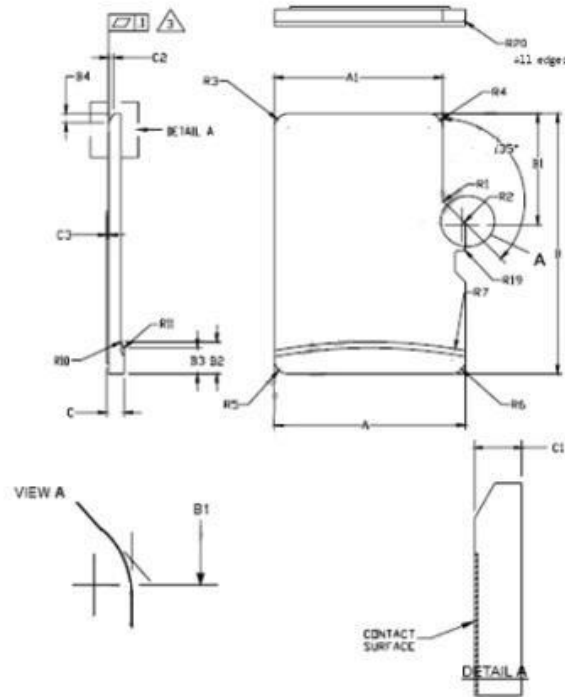

Unit: mm

**For more information,  
contact your Apacer representative**

Global Presence

Taiwan (Headquarters)  
Apacer Technology Inc.  
Tel: +886-2-2267-8000  
Fax: +886-2-2267-2261

Europe  
Apacer Technology B.V.  
Tel: +31-40-267-0000  
Fax: +31-40-290-0686

U.S.A.  
Apacer Memory America, Inc.  
Tel: +1-408-518-8699  
Fax: 1-510-249-9551

China  
Apacer Electronic(Shanghai)  
Co., Ltd.  
Tel: +86-21-6228-9939

Japan  
Apacer Technology Corp.  
Tel: +81-3-5419-2668  
Fax: +81-3-5419-0018

India  
Apacer Technologies Pvt. Ltd.  
Tel: +91-80-41529061~3  
Fax: +91-80-41700215